

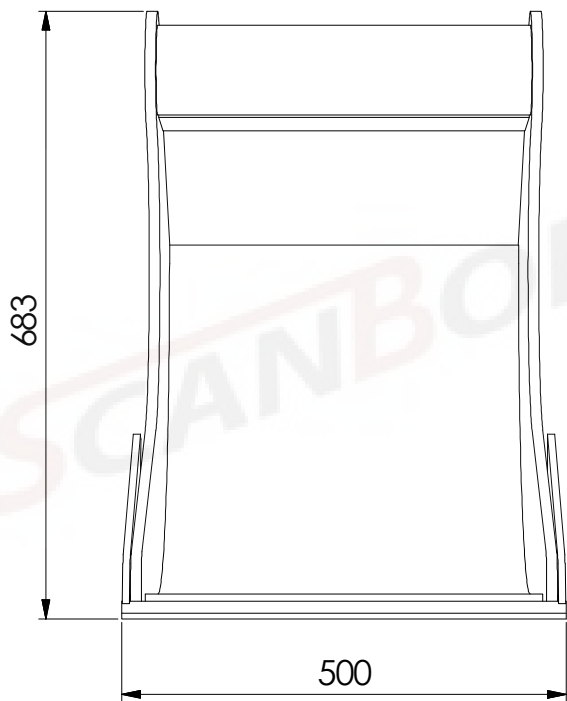

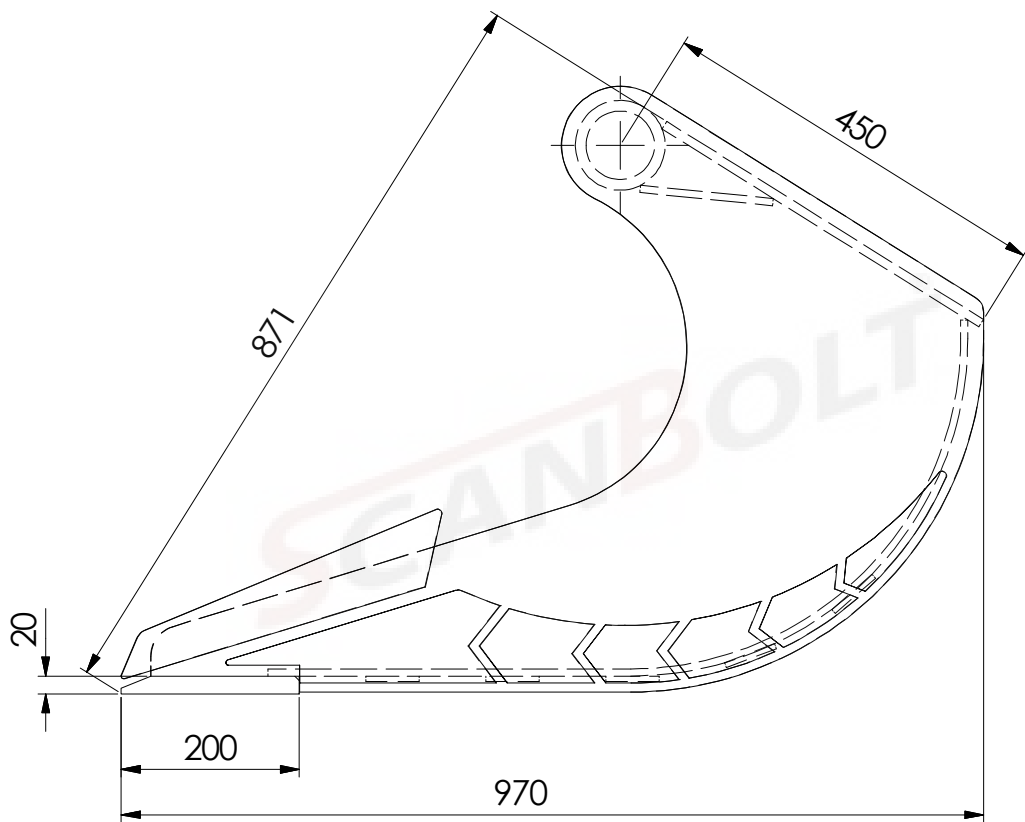

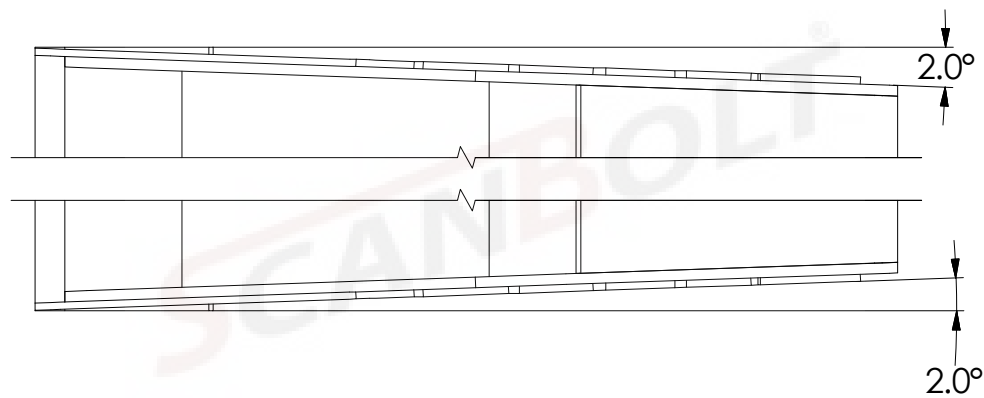

8 7 6 5 4 3 2 1

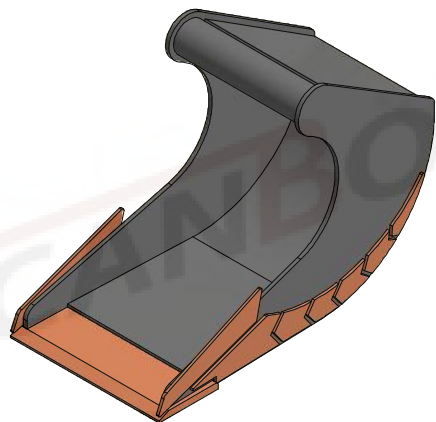

MATERIAL SPECIFICATION	
	ST52.3
	EN8D
	HB 400
	HB 450
	CASTALLOY STEEL

SCANBOLT®	
DESCRIPTION	50 CM CLAY BUCKET
MACHINE CLASS	7.5 - 10 TON
WEIGHT	138 Kg
HEAPED CAPACITY	178 LITERS

8 7 6 5 4 3 2 1